

**botek**<sup>®</sup>

DEEP HOLE DRILLING SYSTEMS  
SOLID CARBIDE TOOLS

# Pilot drill

Type 153-03, 158-08

Stock program



**Solid carbide pilot drill**

coolant fed Type 153-03

**Solid carbide pilot drill**

coolant fed Type 158-08



# Solid carbide pilot drill coolant fed

## Type 153-03

**Coating:** XT  
**Shank:** DIN 6535 HA  
**Point angle:** 140°  
**Nose grind:** SA-0174



DC h5	3 x D				Order No.
	OAL	LCF	DCON h6		
	Over all length	Flute length	Ø Shank		
2.000	50	12	6	702 004 100	
2.500	50	12	6	702 004 101	
3.000	62	15	6	702 004 102	
3.500	62	17	6	702 004 103	
4.000	62	20	6	702 004 104	
5.000	62	25	6	702 004 105	
6.000	66	28	6	702 004 106	
6.500	79	34	8	702 004 107	
7.000	79	34	8	702 004 108	
8.000	79	41	8	702 004 109	
8.500	89	47	10	702 004 110	
9.000	89	47	10	702 004 111	
10.000	89	47	10	702 004 112	
11.000	102	55	12	702 004 113	
12.000	102	55	12	702 004 114	
12.020	107	60	14	702 004 115	
12.500	107	60	14	702 004 116	
12.520	107	60	14	702 004 117	
12.700	107	60	14	702 004 118	
13.000	107	60	14	702 004 119	
13.500	107	60	14	702 004 120	
14.000	107	60	14	702 004 121	
14.020	115	65	16	702 004 122	
14.500	115	65	16	702 004 123	
15.000	115	65	16	702 004 124	
15.020	115	65	16	702 004 125	
15.500	115	65	16	702 004 126	
16.000	115	65	16	702 004 127	
16.020	123	73	18	702 004 128	
16.500	123	73	18	702 004 129	
17.000	123	73	18	702 004 130	
17.500	123	73	18	702 004 131	
18.000	123	73	18	702 004 132	
18.020	131	79	20	702 004 133	
18.500	131	79	20	702 004 134	
19.000	131	79	20	702 004 135	
19.500	131	79	20	702 004 136	
20.000	131	79	20	702 004 137	
20.020	131	79	20	702 004 138	

## Solid carbide pilot drill coolant fed Type 158-08

→ for solid carbide twist drills Type 158

**Coating:** XT  
**Shank:** DIN 6535 HA  
**Point angle:** 145°  
**Nose grind:** SA-0544

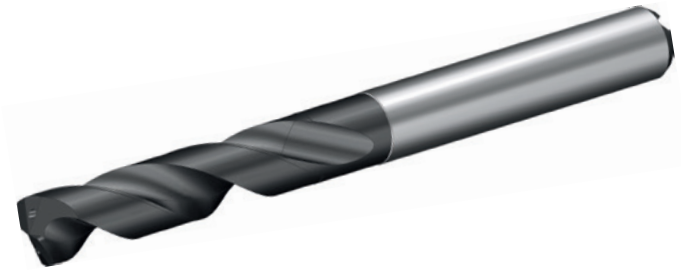

DC h5	3 x D			Order No.
	OAL	LCF	DCON h6	
	Over all length	Flute length	Ø Shank	
3.020	62	17	6	702 006 100
4.020	62	23	6	702 006 101
5.020	66	28	6	702 006 102
6.020	79	34	8	702 006 103
6.520	79	34	8	702 006 104
7.020	79	41	8	702 006 105
8.020	89	47	10	702 006 106
8.520	89	47	10	702 006 107
9.020	89	47	10	702 006 108
10.020	102	55	12	702 006 109
11.020	102	55	12	702 006 110
12.020	107	60	14	702 006 111
12.520	107	60	14	702 006 112
12.720	107	60	14	702 006 113
13.020	107	60	14	702 006 114
13.520	107	60	14	702 006 115
14.020	115	60	16	702 006 116

**FAX to +49 7123 3808 138**

Inquiry

Order (please mark with a cross where applicable)

Customer ID: _____	Order No.: _____
Address: _____	Shipping address: _____
_____	_____
_____	_____
Customer Contact: _____	Phone: _____

Drilling method:  Solid drilling  Blind hole  Precast hole  
 Hole exit under an angle

Material:  Steel  GG/GGG  AL-Si-Leg  \_\_\_\_\_

Machine:  Machining center  Turning and Milling center

Cooling

Internal cooling  External cooling  without cooling  Minimum quantity lubrication

Ø (DC) h5	Length (OAL)	Drilling depth (mm)	Shank		Coating	Pieces	Delivery date
			Shank DIN 6535 HA (Standard)	Special-design			

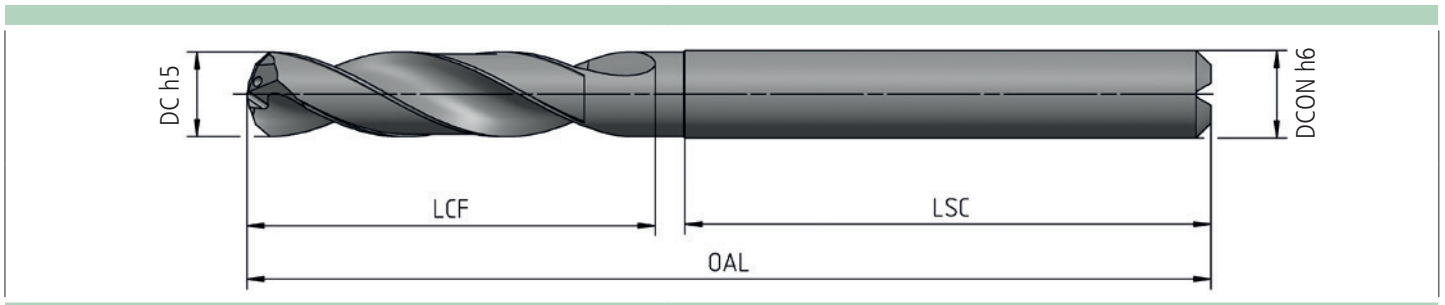

Type 153-03  Type 158-08

Note: \_\_\_\_\_

Mode of Shipment:  UPS (delivery within 2 working days)  TNT 9:00 a.m.  TNT 12:00 a.m.  Pick up

Date: \_\_\_\_\_ Signature: \_\_\_\_\_

A surcharge will be applied depending on delivery requirement. You will be notified to this charge prior to production. The number of tools for express orders is limited.